

EKKO[®]

MATERIAL HANDLING EQUIPMENT

MOVING AHEAD

LITHIUM WALKIE STRADDLE STACKER EB12E-98Li

- LITHIUM LiFePO4
- 2640 lbs. Capacity
- 72 In. Lowered Mast Height
- 98 in. Lift Height
- Narrow Aisles 7 ft.
- Adjustable Legs 45.5-59.1 in.
- Adjustable Forks 8.3-33.5 in.
- 24V Drive Motor
- Curtis Instrument Controller
- Lithium Iron Phosphate Battery, Charger Included
- 3 Year Limited Warranty



EB12E-98Li

Superior quality, maneuverable, compact, and durable for all your material handling applications. Ideal for small aisles and areas.

WEIGHT CAPACITY: 2640 lbs. @ 24" load center

LIFT HEIGHT: 98" (8.1 6ft)

FORK LENGTH: 45.3"

ADJUSTABLE OUTRIGGERS: 45.7" - 59.1"

ADJUSTABLE FORKS: 8.3" - 33.5"

MAST HEIGHT: 72"

TURNING RADIUS: 52.6"

BATTERY / CHARGER: LITHIUM IRON PHOSPHATE
24V/50Ah, internal direct connect 110A 110VAC
plug-in automatic 24V/15A charger (both Included)

SPEED TRAVEL: 3.3 mph empty ; 3.0 mph loaded

LIFTING SPEED: 5.35 ips empty; 3.6 ips loaded

LOWERING SPEED: 3.85 ips empty; 4.4 ips loaded

DRIVE WHEELS: 9" x 3" polyurethane

LOAD WHEELS: (2) 4" x 3" polyurethane per outrigger

HYDRAULICS LIFTING MOTOR: 24V 2200 Watt lifting motor with hardened chrome moly steel for durability.

DRIVE MOTOR: 24V 750Watt drive motor for efficiency and high torque.

AC CONTROLLER: 24V CURTIS Instrument provides performance through entire range of speed; Constant travel speed regardless of load; Battery discharge indicator combination gauge.

BRAKES: Electro-magnetic braking for secure stopping power; Electronic neutral braking for accurate control.

OPERATOR CONTROLS: Throttle, lifting, lowering, turtle mode and horn functions are located in the ergonomic handle; Offset steering handle to provide better visibility; Belly button reverse safety feature allows the unit to stop and reverse to avoid collision or injury.

CHASSIS AND MAST: Robotic Welding; Heavy duty steel chassis with I-beam mast for durability; Telescoping mast includes a protective steel guard.



LITHIUM STRADDLE STACKER



Model		EB12E -98Li
Power unit		Walkie
Operate type		Electric
Load capacity	Q (LBS)	2640
Load Center	c (Inch)	24
Axle center to fork face	x (Inch)	28
WheelBase	y (Inch)	45.4
Service weight	LBS	1300
Tyres		Polyurethane wheels
Front wheel size,number	Φxw(Inch)	Φ3.1 x2.7 ,4
Rear wheel size ,number	Φxw(Inch)	Φ8.3*2.7,1
Balance wheel size,number	Φxw(Inch)	Φ6*2.3 1
Lowered mast height	h1 (Inch)	72.05
the max Lift height	h3 (Inch)	98.42
Extended mast height	h4 (Inch)	119.96
Operating handle height at drive position (min/Max)	h14 (Inch)	34.25/47.24
Lower fork height	h13 (Inch)	2.56
Overall Length	l1 (Inch)	71
Length to Fork face	l2 (Inch)	23.82
Fork Dimension:	s/e/l (Inch)	1.38/3.94/45.28
Outside width between two fork	b5 (Inch)	8.27-33.47
Min ground clearance	m2 (Inch)	0.95
Turning radius	Wa (Inch)	52.6
Travel speed, laden/unladen	km/h	4.0/4.2
Lift speed, laden/unladen	m/s	92/136
Lowering speed. Laden/unladen	m/s	112/98
Maximum climbing ability Laden/unladen	%	6/8
Service brake		Electromagnetic
Life motor	kw	2.2
Driving motor	kw	0.75
Steering motor	kw	/
Battery according to Din 43531/35/36 a,b,c		no
Lithium Iron Phosphate LiFePO4 Battery voltage, nominal capacity	v/ah	24 V/50AH
battery weight	LBS	29
Type of control		DC
Noise level at operator's ear		69
Steering type		Mechanical

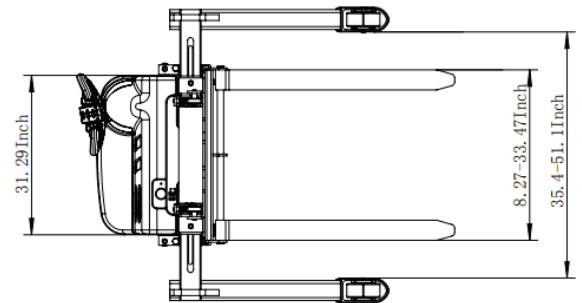
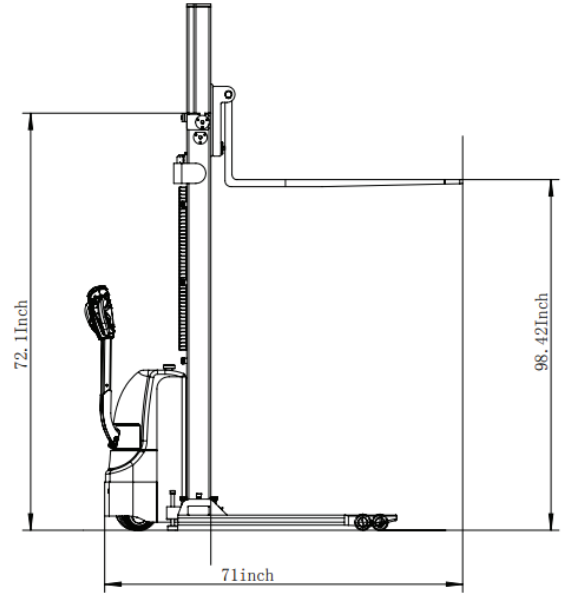

MODEL #	MAST	LIFT HEIGHT	MAX MAST HEIGHT	SERVICE WEIGHT
EB12E-98Li	72"	98"	154"	1300



10268 West Jefferson Avenue
 River Rouge, Michigan 48218
 T: (313) 843-6466

AUTHORIZED DEALER
www.hiloindustrial.com