

# EKKO<sup>®</sup>

MATERIAL HANDLING EQUIPMENT

**MOVING AHEAD**

## 4-WHEEL ELECTRIC FORKLIFT EK20R SERIES

- Load Capacity 4500 lbs.
- Lift Height 189-216 in. 3 Stage
- Side Shifting Forks
- 48V420Ah Industrial Batteries
- Free Lift 68-77"
- Hydraulic Power Steering
- Length 129"
- Curtis Controller
- Tilt 3/6 degree
- Mast Height 84-93"
- Overhead Guard 86.5"
- Batteries & Charger
- 3 Year Limited Warranty



## EK20R

Superior quality, maneuverable, compact, and durable for all your material handling applications. Ideal for small aisles and areas.

**WEIGHT CAPACITY:** 4500 lbs. @ 24" load center

**LIFT HEIGHT:** 189-216 3 Stage

**SIDE SHIFTING FORKS:** 45.3"

**MAST HEIGHT:** 84-93"

**TURNING RADIUS:** 84.6"

**FREE LIFT:** 68-77"

**TILT:** 3/6 degree

**INDUSTRIAL BATTERY / CHARGER:** 48V 420Ah, Industrial batteries with external direct connect 210A 210VAC plug-in automatic 48V/65A charger (both Included)

**BRAKING:** Drum brakes

**SPEED TRAVEL:** 9 mph empty ; 7.5 mph loaded

**LIFTING SPEED:** 16 ips empty; 9.9 ips loaded

**LOWERING SPEED:** 10.2 ips empty; 9.5 ips loaded

**FRONT WHEELS:** 6.5x10x10" solid cushion

**REAR WHEELS:** 5x8x10" solid cushion

**HYDRAULICS LIFTING MOTOR:** 48V 7700 Watt lifting motor with hardened chrome moly steel for durability.

**DRIVE MOTOR:** 48V 7500 Watt ZF AC drive motor for efficiency and high torque.

**AC CONTROLLER:** 48V Curtis provides performance through entire range of speed; Constant travel speed regardless of load; Battery discharge indicator combination gauge.

**BRAKES:** Drum Brakes with Electro-magnetic braking for secure stopping power

**LIGHTING:** LED Head lights, turn signals and brake lights.

**OPERATOR CONTROLS:** Tilt, lifting, lowering, side shifting forks, horn functions are located in the ergonomic sit down; Led lighting.

**CHASSIS AND MAST:** Robotic Welding; Heavy duty steel chassis with I-beam mast for durability; Telescoping mast.



# 4-Wheel Electric Forklift

# EKKO®

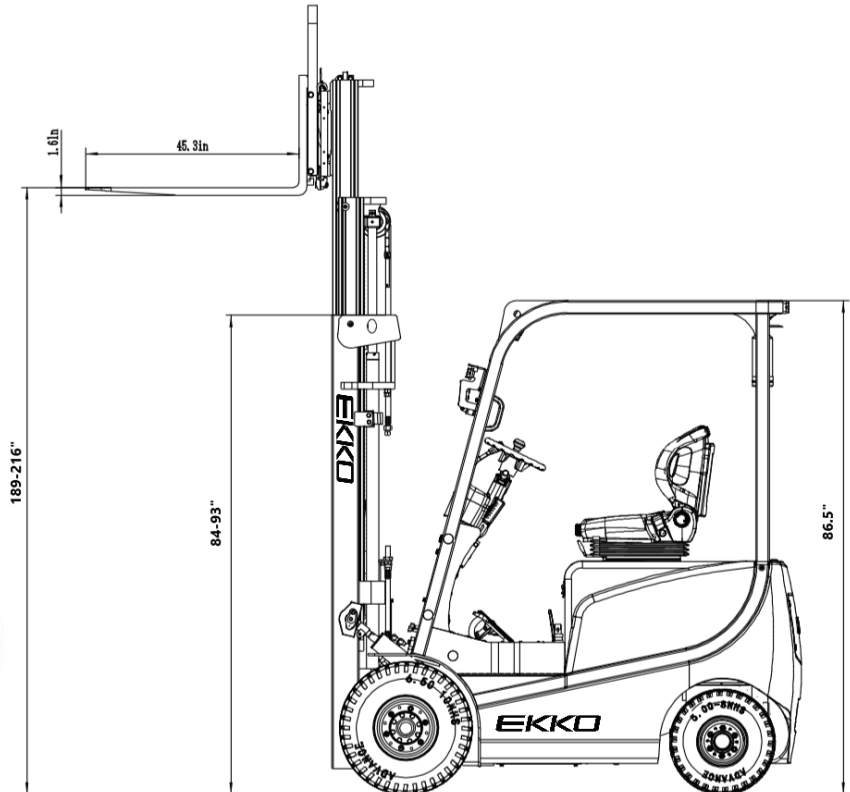
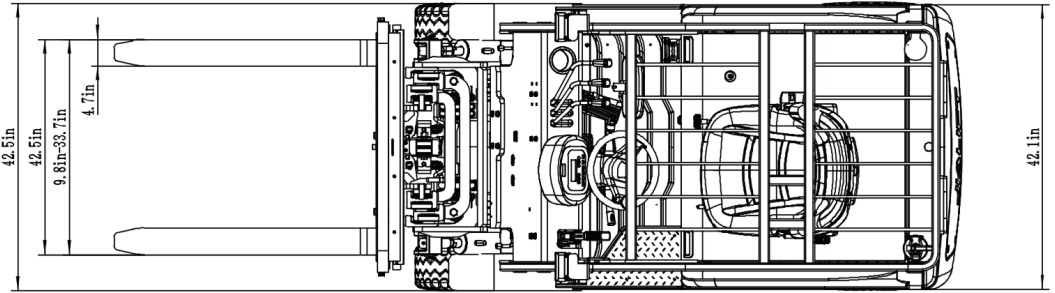

MODEL #	LOWERED MAST	LIFT HEIGHT	FREE LIFT	MAX MAST HEIGHT	TOTAL LENGTH	SERVICE WEIGHT
EK2OR	93"	216"	77"	249"	129"	8000lbs
EK2ORL	84"	189"	68"	221"	129"	7500lbs



10268 West Jefferson Avenue  
 River Rouge, Michigan 48218  
 T: (313) 843-6466

AUTHORIZED DEALER  
[www.hiloindustrial.com](http://www.hiloindustrial.com)